

BROILMASTER® **PREMIUM GAS GRILLS**

Owner's Manual For Models: Q3X-1 Q3XN-1

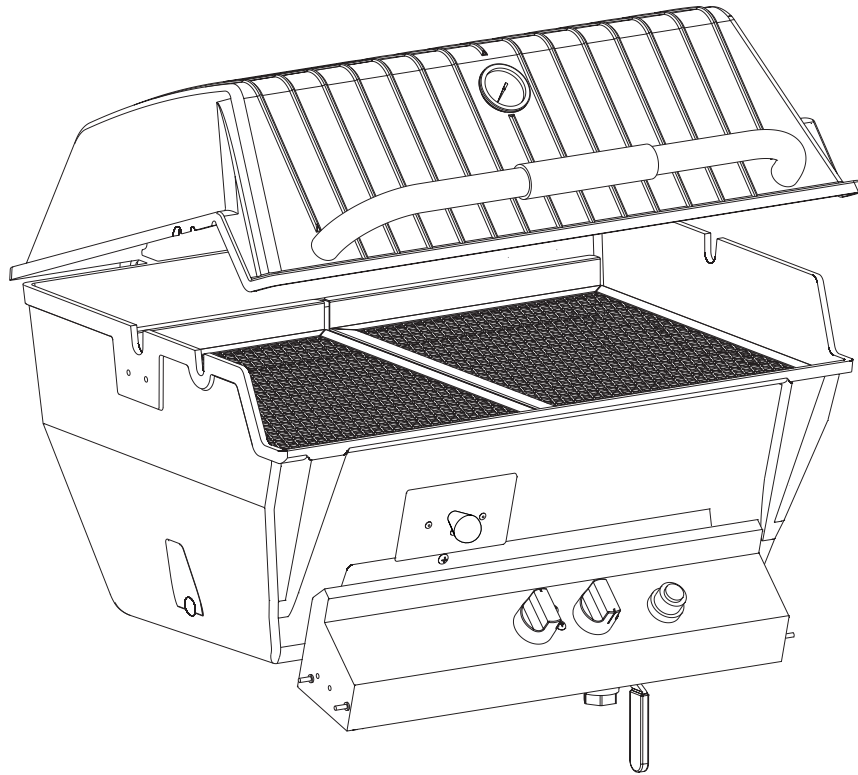

IMPORTANT

This manual should be read thoroughly by the person installing the grill and all persons who will use and maintain the grill. The installer should be sure the manual is left in the possession of the user. The user should retain this manual for future reference when using or cleaning the grill and to properly identify any repair parts that may be required.

▲ WARNING

Reference this manual for proper installation and maintenance instructions. Improper installation, adjustment, alteration, service or maintenance can cause personal injury or property damage. For assistance or additional information consult a qualified installer, service agency or the gas supplier.

▲ DANGER: FOR YOUR SAFETY

IF YOU SMELL GAS:

1. Shut off gas to the grill.
2. Extinguish any open flame.
3. Open the grill lid.
4. If odor continues, keep away from the appliance and immediately call your gas supplier or your fire department.

▲ WARNING: FOR YOUR SAFETY

1. Do not store or use gasoline or other flammable vapors or liquids in the vicinity of this or any other appliance.
2. An LP cylinder not connected for use shall not be stored in the vicinity of this or any other appliance.

▲ CAUTION:

Parts may have sharp edges. Wear leather work gloves and handle parts carefully during the unpacking, assembly and installation.

▲ WARNING

Broilmaster Gas Grills must **ONLY** use propane cylinders equipped with an Overfill Protection Device (OPD). Use only a reputable propane dealer when exchanging or filling cylinders. An overfilled or improperly filled propane cylinder can be dangerous.

Congratulations!

Welcome to the beauty, durability, and prestige of a Premium Gas Grill by Broilmaster. With award-winning excellence built into every feature and durability that surpasses other Premium gas grills, Broilmaster has manufactured the ultimate gas grill for discriminating outdoor chefs for over 30 years.

At Broilmaster, we continually strive to enhance the performance and quality of our products for your grilling enjoyment. Every effort will be made to ensure that Broilmaster continues to be your choice as the Premium grill of the future.

Whether you are at the lake or in the privacy of your own backyard, the Broilmaster Premium Gas Grill performs far beyond the ordinary and is designed to provide your family with years of outdoor cooking pleasure.

Thank You!

Broilmaster is a registered trademark of

Empire Comfort Systems, Inc.

918 Freeburg Ave.

Belleville, Illinois 62220

Telephone 800-851-3153

PARTS DIAGRAM

Order repair parts through your local Broilmaster dealer. To locate a dealer in your area visit www.broilmaster.com. Please provide the following information when placing a repair part order: Model Number, Purchase Date, Serial Number, Part Name, Part Number, and Quantity of parts needed. See Page 7 for parts ordering information.

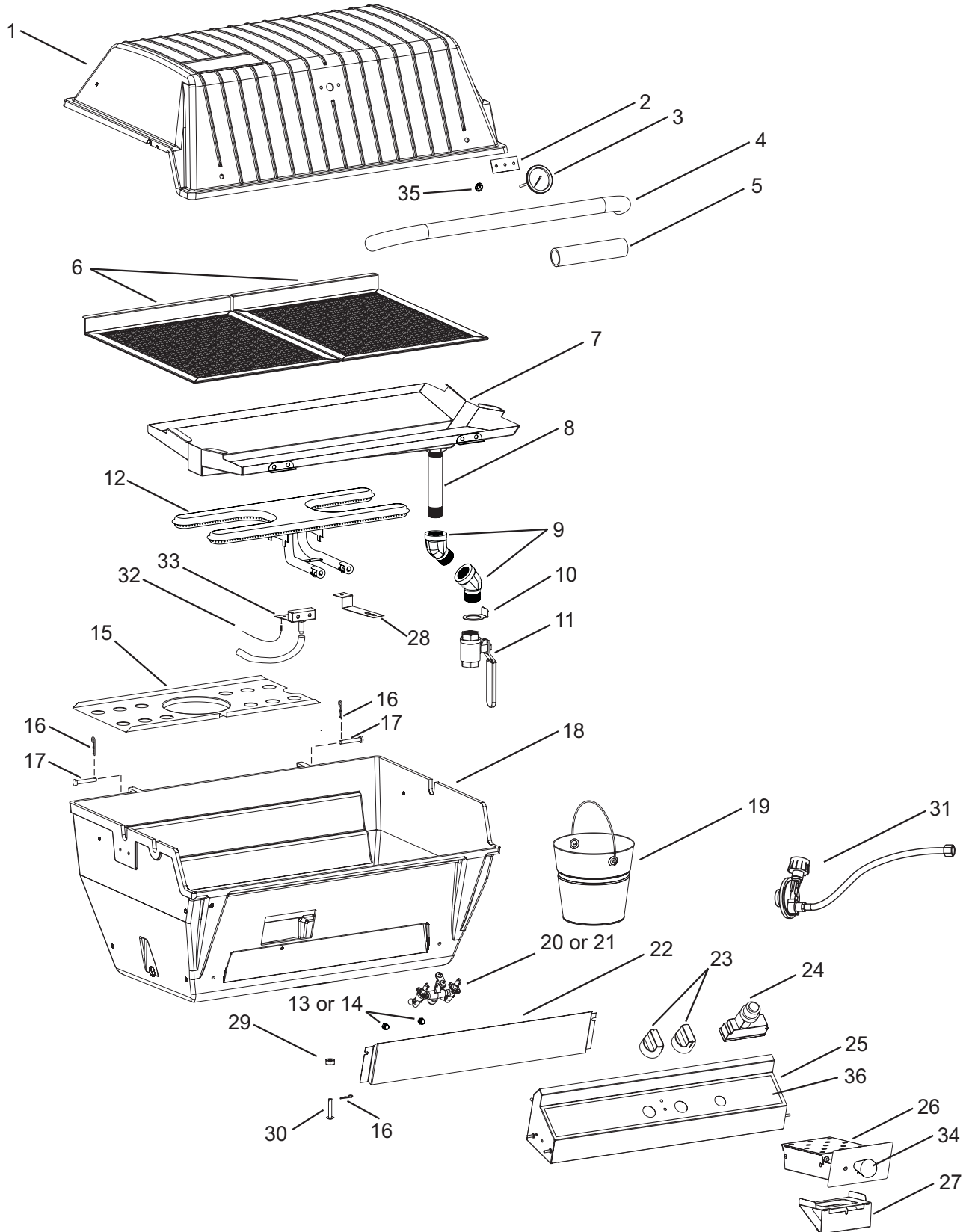

PARTS LIST

INDEX NUMBER	PART NUMBER		DESCRIPTION
	Q3X	Q3XN	
1	B100456	B100456	GRILL BODY TOP
2	B101782	B101782	MOUNTING PLATE, HEAT INDICATOR
3	B101736	B101736	HEAT INDICATOR
4	B070486	B070486	LID HANDLE
5	B073097	B073097	FOAM GRIP
6	B101732	B101732	COOKING SCREEN (2 PIECES, STAINLESS STEEL)
7	B101718	B101718	DRIP PAN (STAINLESS)
8	B101747	B101747	5.5" NIPPLE (DRIP TRAY DRAIN PIPE)
9	B101769	B101769	45* STREET EL (2 PCS., DRIP TRAY DRAIN)
10	B101780	B101780	BUCKET HOOK
11	B101778	B101778	DRAIN PIPE SHUT OFF VALVE
12	B101733	B101733	BURNER ASSEMBLY
13	P315	-	ORIFICE, #60
14	-	P208	ORIFICE, 1.45mm
15	B101742	B101742	CONTROL PANEL SHIELD
16	B057805	B057805	BRIDGE PIN
17	B057804	B057804	HINGE PIN
18	B101739	B101739	GRILL BODY BOTTOM
19	B101779	B101779	BUCKET
20	B101420	-	VALVE - LP
21	-	B101421	VALVE - NAT
22	B101622	B101622	SHIELD, CONTROL PANEL
23	B070084	B070084	VALVE KNOB
24	B072218	B072218	ELECTRIC IGNITOR
25	B100743	B100743	CONTROL PANEL ASSEMBLY
26	B101724	B101724	SMOKER BOX
27	B101781	B101781	DRAWER SUPPORT
28	B101648	B101648	BURNER BRACKET
29	B076331	B076331	NUT, BURNER BRACKET
30	B101649	B101649	MACHINE SCREW, BURNER BRACKET
31	B069756	-	HOSE AND REGULATOR
32	B072684	B072684	IGNITOR GROUND WIRE
33	B101805	B101805	COLLECTOR BOX ASSEMBLY
34	B062998	B062998	SMOKER KNOB
35	B101665	B101665	PUSH NUT, 5/32"
36	B101517	B101517	CONTROL PANEL LABEL

HARDWARE PACKAGE

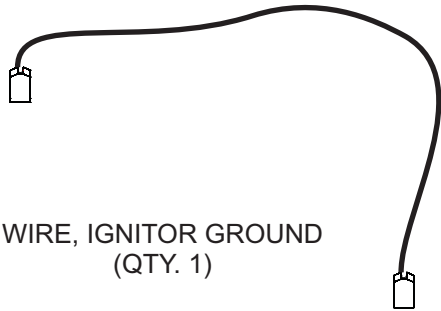

WIRE, IGNITOR GROUND
(QTY. 1)

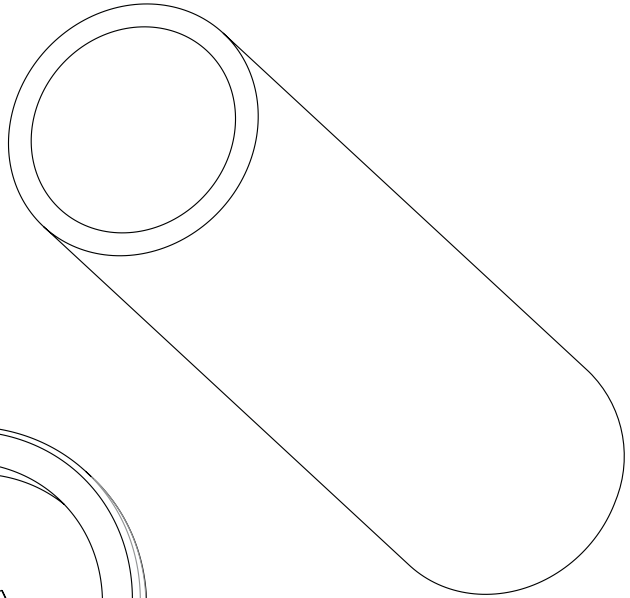

FOAM GRIP
(QTY. 1)

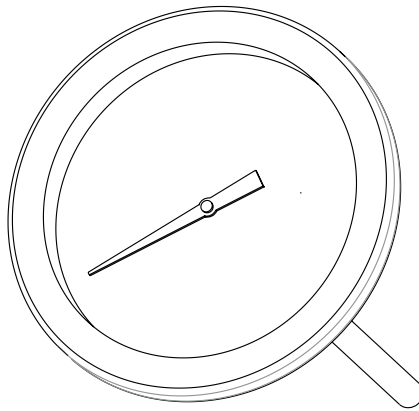



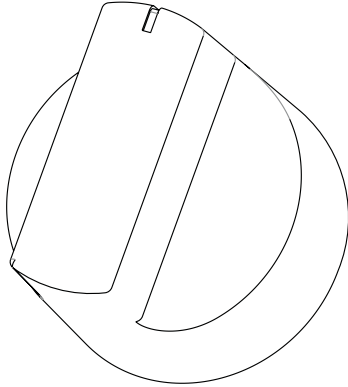

HEAT INDICATOR
(QTY. 1)

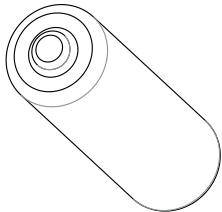

KNOB, VALVE
(QTY. 2)

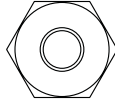
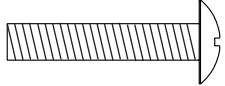

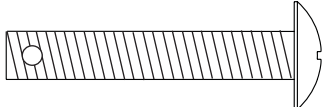
AA BATTERY
(QTY. 1)

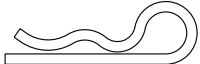
 1/4-20 NUT, SS (QTY. 1)	 10-24 SCREW, SS (QTY. 3)
 5/32" PUSH NUT (QTY. 1)	 1/4-20 SCREW W/ HOLE (QTY. 1)
 10-24 SS KEEPS NUT (QTY. 3)	 BRIDGE PIN (QTY. 1)

1:1 SCALE

MASTER PARTS DISTRIBUTOR LIST

To Order Parts Under Warranty, please contact your local Empire dealer. See the dealer locator at www.empirecomfort.com. To provide warranty service, your dealer will need your name and address, model number, purchase date and serial number, and the nature of the problem with the unit.

To Order Parts After the Warranty Period, please contact your dealer or one of the Master Parts Distributors listed below. This list changes from time to time. For the current list, please click on the Master Parts button at www.empirecomfort.com. Please note: Master Parts Distributors are independent businesses that stock the most commonly ordered Original Equipment repair parts for Heaters, Grills, and Fireplaces manufactured by Empire Comfort Systems Inc.

Dey Distributing

1401 Willow Lake Boulevard
Vadnais Heights, MN 55101

Phone: 651-490-9191

Toll Free: 800-397-1339

Website: www.deyistributing.com

Parts: Heater, Hearth and Grills

East Coast Energy Products

10 East Route 36
West Long Branch, NJ 07764

Phone: 732-870-8809

Toll Free: 800-755-8809

Fax: 732-870-8811

Website: www.eastcoastenergy.com

Parts: Heater, Hearth and Grills

Victor Division of F. W. Webb Company

200 Locust Street
Hartford, CT 06114

Phone: 860-722-2433

Toll Free: 800-243-9360

Fax: 860-293-0479

Toll Free Fax: 800-274-2004

Websites: www.fwwebb.com & www.victormfg.com

Parts: Heater, Hearth and Grills

HOW TO ORDER REPAIR PARTS

Parts Not Under Warranty

Parts can be ordered through your Service Person, Dealer, or a Master Parts Distributor. See this page for the Master Parts Distributors list. For best results, the **service person or dealer** should order parts through the distributor. Parts can be shipped directly to the **service person/dealer**.

Warranty Parts

Warranty parts will need a proof of purchase and can be ordered by your Service Person or Dealer. Proof of purchase is **required** for warranty parts.

All parts listed in the Parts List have a Part Number. When ordering parts, first obtain the Model Number and Serial Number from the name plate on your equipment. Then determine the Part Number (**not** the Index Number) and the Description of each part from the following illustration and part list. Be sure to give all this information . . .

Appliance Model Number _____ Part Description _____

Appliance Serial Number _____ Part Number _____

Type of Gas (Propane or Natural) _____

Do not order bolts, screws, washers or nuts. They are standard hardware items and can be purchased at any local hardware store.

Shipments contingent upon strikes, fires and all causes beyond our control.

WARRANTY TERMS

Empire Comfort Systems Inc. warrants this Broilmaster premium gas grill to be free from defects at the time of purchase and for the periods specified below. Broilmaster Premium Gas Grills must be installed by a qualified technician and must be maintained and operated safely, in accordance with the instructions in the owner's manual. This warranty applies to the original purchaser only and is not transferable. All warranty repairs must be accomplished by a qualified gas appliance technician.

Limited Lifetime Parts Warranty – Against Rust-Through

If the items listed below fail because of defective workmanship or material, Empire will repair or replace at Empire's option. The limited lifetime warranty provides one-time replacement of a covered component.

- Aluminum Grill Housing (except paint)
- Stainless Steel Cooking Grids and Stainless Steel Griddles
- Select Stainless Steel Components – Cart, Mounting, Bowtie Burner, Side Burner (DPSBSS), Side Burner Housing, and Warming Rack
- Stainless Steel Built-In Components – Built-In Kits for 3-Series Grill Heads, Door Kit, Tilt-Out LP Tank Door, and Vent Register Kit

Limited Ten-Year Parts Warranty – Against Rust-Through

If the items listed below fail because of defective workmanship or material, Empire will repair or replace at Empire's option.

- Stainless Steel Burners for H-Series, Q-Series, and R3B
- Drip Pan for Q-Series
- Side Burner (DPASBC), Side Burner Housing (BSA)

Limited Five-Year Parts Warranty – Against Rust-Through

If the items listed below fail because of defective workmanship or material, Empire will repair or replace at Empire's option.

- Infrared Burners on R3 or R3B
- Flare Buster™ Ceramic Flavor Enhancers
- Painted Electro-Galvanized Steel Components
- Stainless Steel Smoker Shutter

Limited Two-Year Parts Warranty – Against Rust-Through

If the items listed below fail because of defective workmanship or material, Empire will repair or replace at Empire's option.

- Porcelain Coated Steel Briquette Racks
- Chrome-Plated Warming Rack
- Stainless Steel Flavor Screen
- Stainless Steel Heat Shield

Limited One-Year Parts Warranty

If the items listed below fail because of defective workmanship or material, Empire will repair or replace at Empire's option.

- Valves, knobs, ignitors, labels, hoses, fittings, grease cups, drip buckets, and all other parts and accessories – including those made from stainless steel – unless specified above
- Paint on Aluminum Grill Head

Duties Of The Owner

The appliance must be installed by a qualified installer and operated in accordance with the instructions furnished with the appliance.

A bill of sale, cancelled check, or payment record should be kept to verify purchase date and establish warranty period.
Ready access to the appliance for service.

What Is Not Covered

Damages that might result from the use, misuse, or improper installation or storage of this appliance.

Travel, diagnostic costs and freight charges on warranted parts to and from the factory.

Claims that do not involve defective workmanship or materials.

Unauthorized service or parts replacements.

Removal and reinstallation cost.

Inoperable due to improper or lack of maintenance.

The costs of a service call to diagnose a problem and labor for replacement or repairs.

How To Get Service

To make a claim under this warranty, please have your receipt available and contact your installing dealer. Provide the dealer with the model number, serial number, type of gas, and purchase verification. The installing dealer is responsible for providing service and will contact the factory to initiate any warranted parts replacements. Empire will make replacement parts available at the factory. Shipping expenses are not covered.

If, after contacting your Empire dealer, service received has not been satisfactory, contact: Consumer Relations Department, Empire Comfort Systems Inc., PO Box 529, Belleville, Illinois 62222, or send an e-mail to info@empirecomfort.com with "Consumer Relations" in the subject line.

Your Rights Under State Law

This warranty gives your specific legal rights, and you may also have other rights, which vary from state to state.

Broilmaster is a Division of Empire Comfort Systems, Inc.

GRILL ASSEMBLY

Before You Begin

All Broilmaster grills require some assembly and installation. Follow all instructions unless noted to apply only to other specific models.

If you purchased an accessory with your Broilmaster, follow the instructions provided with the accessory for assembly and installation. If an instruction refers to a step that is not required for your grill model, please continue to the next step.

Compare the parts found in the shipping container to the parts list provided. If any parts are missing contact your Broilmaster dealer before beginning assembly.

CAUTION: Parts may have sharp edges. Wear leather work gloves and handle parts carefully during the unpacking, assembly and installation.

Recommended Tools

These items are recommended for the assembly of your grill:

Do NOT use power tools.

- Channel locks or pipe wrench
- Phillips screwdriver
- Adjustable wrench set
- Socket set
- Soapy water solution (to test for leaks)
- Liquid soap (for foam grip)
- Pipe sealant or Teflon tape (for sealing pipe fittings)

Grill Mountings

Assemble your base option before assembling your Broilmaster grill head.

Refer to the Broilmaster Cart, Base, and Post instructions provided with each accessory for assembly, installation, and mounting procedures.

Note: Built-in Kit can not be used with Grave Grills.

PROPANE GAS GRILLS

Grill Location

When choosing the ideal location for your Broilmaster Premium Gas Grill, remember this grill is designed for outdoor use ONLY.

Never install or operate your grill in any building, garage, or other enclosed area.

For your safety, this grill should not be installed or operated under any combustible materials, such as carports, covered porches, awnings, or overhangs.

Never install or operate your grill in or on any recreational vehicle or boat.

CAUTION: The installation and operation of this grill at clearances less than specified below may lead to the possibility of fire, property damage, or personal injury.

A minimum clearance of sixteen inches (16") is required from the sides of the grill to any combustible material.

A minimum clearance of eighteen inches (18") is required from the back of the grill to any combustible material.

Some examples of combustible materials are a wall, a fence, patio furniture, or the wall of your home.

The area surrounding the grill should be clear to ensure proper ventilation. Do not obstruct the flow of combustion and ventilation air in any way. The ventilation openings on the propane cylinder enclosure must also remain free and clear of debris.

Portable grills should be level and positioned away from direct wind prior to each use.

⚠ WARNING: Do not install or operate this grill where gasoline or other flammable materials are used or stored. Failure to comply with this warning could result in explosion or fire causing property damage or personal injury.

Cylinder Requirements

Your Broilmaster Premium Gas Grill requires a standard twenty (20) pound propane gas cylinder.

The maximum height allowable for a replacement cylinder is approximately twelve (12") inches (30.5 centimeters)

The propane gas cylinder used must be:

1. Constructed and marked in accordance with the specifications for LP gas cylinder of the U.S. Department of Transportation (D.O.T.) or the National Standard of Canada, CAN/CSA-B339, Cylinders, Spheres, and Tubes for Transportation of Dangerous Goods; and Commission as applicable.
2. Provided with a listed overfilling protection device (OPD).
3. Provided with a listed safety device having direct access with the vapor space of the cylinder and the cylinder supply system must be arranged for vapor removal.
4. Provided with a shutoff valve terminating in a valve outlet as specified in the Standard for Compressed Gas Cylinder Outlet and Inlet Connections, ANSICGA-V-1.
5. Provided with a plug to effectively seal off the cylinder outlet when the cylinder is being stored or transported.
6. Provided with a collar to protect the cylinder valve.

Caution: Do not use a propane gas cylinder which has a capacity greater than twenty (20) pounds with this grill and side burner.

PROPANE GAS GRILLS

Propane Cylinder Safety

Liquid Propane (LP) gas has a long history of safe use when the safety precautions provided in this manual are followed.

Failure to follow these safety precautions could result in a fire or explosion causing property damage or personal injury.

Propane gas cylinders should always be handled, stored, and transported with extreme caution in a secured upright position.

Never attempt to use or repair a propane gas cylinder that has been damaged. Never attempt to use or repair a cylinder with a faulty or damaged valve outlet. A cylinder that has been dropped, dented, or otherwise damaged must be replaced.

A propane gas cylinder should never be transported in the passenger area of a vehicle.

Keep cylinders out of direct sunlight and never apply any other source of direct heat to them.

When refilling your cylinder, always insist on a reputable, qualified gas dealer. Your propane gas cylinder is filled by weight, and should never exceed eighty percent (80%) of its weight limit. If the cylinder is not completely empty, the gas dealer must make necessary adjustments to ensure it is not overfilled. Never use an overfilled Propane gas cylinder.

Cylinder Storage

Your grill must be stored outdoors in a well ventilated area if the cylinder is attached to it.

Disconnected cylinders must have a threaded valve plug tightly installed and must not be stored in any building, garage, or other enclosed area.

Flammable materials (gasoline, grill covers, etc.) must not be stored in the cylinder enclosure.

Always store Propane cylinders in a secured upright position, out of the reach of children.

Connection Requirements

Caution: Never use Liquid Propane (LP) gas in a grill designed for Natural gas, or Natural gas in a grill designed for Liquid Propane gas. Questions regarding different types of gases should be directed to your local gas supplier.

Installation must conform to local codes or, in the absence of local codes, with the National Fuel Gas Code, ANSI Z223.1. In Canada, installation shall be in accordance with CAN/CGA-B149.2 Propane Installation Code, or CAN/CGA-B149.1 Natural Gas Installation Code, and local codes where applicable. Consult your local gas supplier or propane gas dealer for code regulations and recommended procedures.

⚠ Warning: Broilmaster Premium Gas Grills require Liquid Propane (LP) cylinders equipped with an Overfill Protection Device (OPD). An overfilled or improperly filled Propane cylinder can be dangerous.

Always use the pressure regulator and hose assembly supplied with your Propane gas grill.

Note: Not all valve and cylinder combinations are compatible. Check warning tag on valve and cylinder as well as external fitting threads.

All Broilmaster pressure regulators and hose assemblies require Propane cylinders with a Type 1 connection device as illustrated. **See Figure 1.**

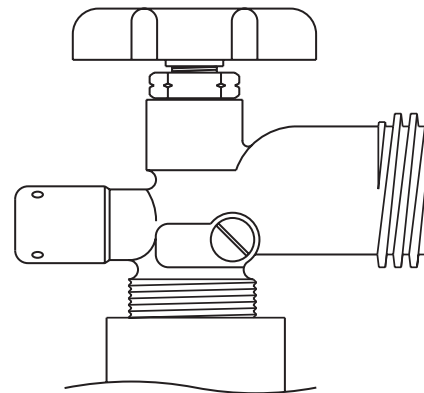

Figure 1

PROPANE GAS GRILLS

Pressure Regulator and Hose Assembly

The pressure regulator has an outlet pressure of not more than eleven (11") inches water column. It must be connected to the Propane gas cylinder's valve outlet before the grill can be operated.

Caution: Operation of a Propane gas grill without the pressure regulator and hose assembly will cause gas leaks which could lead to fire or explosion, resulting in property damage or personal injury.

The pressure regulator's fitting must remain clean and free of nicks and scratches. A dirty, nicked or scratched fitting can cause a gas leak, resulting in an explosion or fire. Use only genuine Broilmaster replacement parts unless otherwise specified by the manufacturer.

Connecting to Propane Gas / Cylinder Retention Means

ATTENTION: Propane gas cylinders that are acceptable for use with this grill must comply with Cylinder Requirements, Page 10, and Connection Requirements, Page 11.

Position the cylinder in the opening in the bottom of the cart and secure with the cylinder retaining bracket. **See Figure 2.**

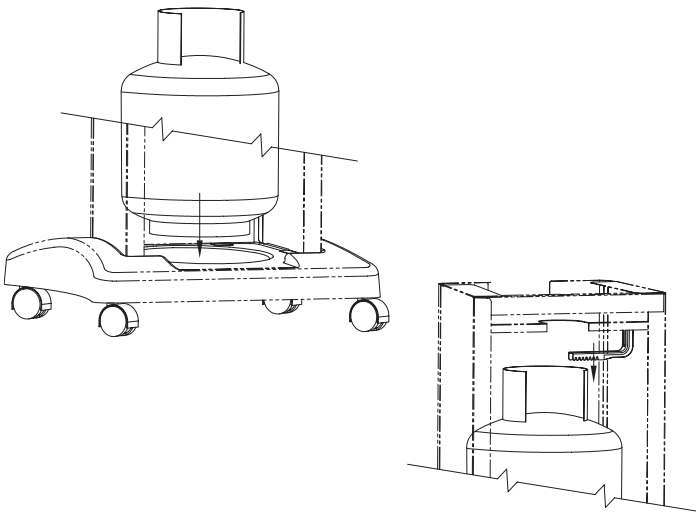

Figure 2

Attach the pressure regulator to the Propane gas cylinder's valve using the plastic handwheel. Tighten in a clockwise motion to achieve a gas tight seal. **See Figure 3.**

Caution: Do not use a wrench or any other tool to tighten. Use of a wrench or other tool will damage the plastic handwheel.

To disconnect the Propane gas cylinder, turn OFF the cylinder's valve and the grill's control valve. Remove the regulator by turning the plastic handwheel counterclockwise.

Caution: Assure hose does not touch the casting or mounting components.

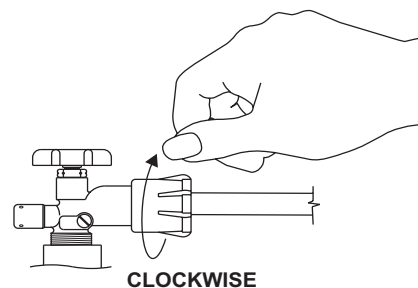

CLOCKWISE

Figure 3

NATURAL GAS GRILLS

Grill Location

When choosing the ideal location for your Broilmaster Premium Gas Grill, remember this grill is designed for outdoor use ONLY.

You should never install or operate your grill in any building, garage, or other enclosed area.

For your safety, this grill should not be installed or operated under any combustible materials, such as carports, covered porches, awnings, or overhangs.

Never install or operate your grill in or on any recreational vehicle or boat.

CAUTION: The installation and operation of this grill at clearances less than specified below may lead to the possibility of fire, property damage, or personal injury.

A minimum clearance of sixteen (16") inches is required from the sides of the grill to any combustible material.

A minimum clearance of eighteen (18") inches is required from the back of the grill to any combustible material.

Some examples of combustible materials are a wall, a fence, patio furniture, or the wall of your home.

The area surrounding the grill should be clear to ensure proper ventilation. Do not obstruct the flow of combustion and ventilation air in any way. The ventilation openings on the propane cylinder enclosure must also remain free and clear of debris.

Portable grills should be level and positioned away from direct wind prior to each use.

⚠ WARNING: Do not install or operate this grill where gasoline or other flammable materials are used or stored. Failure to comply with this warning could result in explosion or fire causing property damage or personal injury.

Gas Type

The type gas required for your grill can be determined from the product identification label located on the grill's control panel. Questions regarding different types of gases should be directed to your local gas supplier.

Caution: Never use Liquid Propane (LP) gas in a grill designed for Natural gas, or Natural gas in a grill designed for Liquid Propane gas. Questions regarding different types of gases should be directed to your local gas company.

Connection Requirements

Broilmaster grills are not equipped with pressure regulators. Your gas grill operates at a manifold pressure of seven (7") inches water column.

Connect cart mounted Natural gas grills to a pre-installed gas supply line using the twelve (12') foot flexible hose and quick disconnect kit which can be purchased from your local dealer.

Hazardous Locations and Conditions

- The LP gas cylinder must be arranged upright for vapor withdrawal.
- Do not obstruct the flow of combustion and ventilation air.
- This grill should only be used outdoors in a well-ventilated space must not be used in a building, garage, or any other enclosed area.
- Keep all flammable substances away from the grill. These include most aerosols and aerosol containers, gasoline and similar liquids, paper and paper products, containers of grease, paint, etc.
- Never store flammable materials or objects such as those described above in the pedestal base.
- Never leave grill unattended while in operation.
- Never use any liquid in an attempt to control flare-up.
- It may be necessary to adjust your grill away from the direction of prevailing wind.
- Avoid wearing flammable and/or loose clothing such as long-sleeves, neckties, scarves, aprons, etc., while the grill is in operation.
- Avoid contact of hair to heat and flames.

Caution: The grill and its individual shutoff valve must be disconnected from the gas supply piping system during any system pressure testing at test pressures in excess of 1/2 PSIG.

Caution: The grill must be isolated from the gas supply piping system by closing its individual manual shutoff valve during any pressure testing of the gas supply piping system at test pressures equal to or less than 1/2 PSIG.

GRILL ASSEMBLY

To ease installation remove grill body top from grill body bottom by removing the two hinge pins and clips.

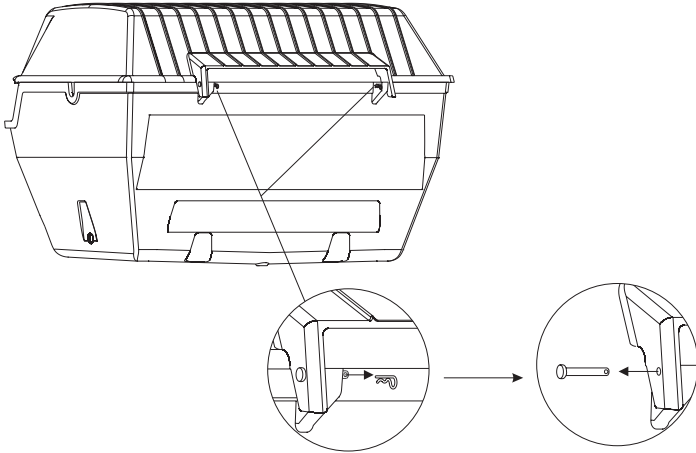

Figure 4

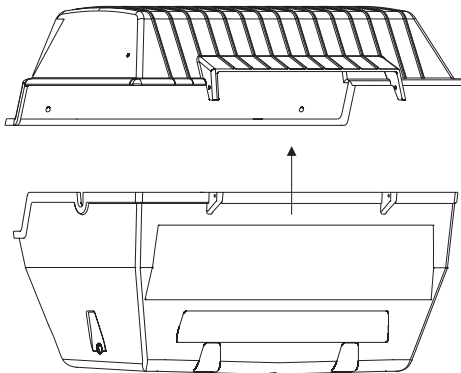

Figure 5

Install Hose and Regulator (For LP Models)

Attach the hose and regulator supplied with the unit as shown in Figure 6.

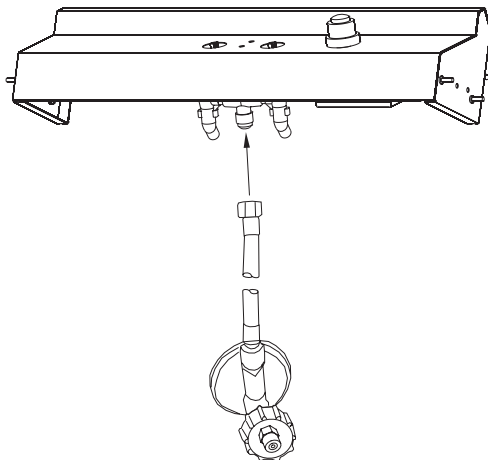

Figure 6

Install Heat Shield

Attach shield by inserting the shield over the studs. See Figure 7.

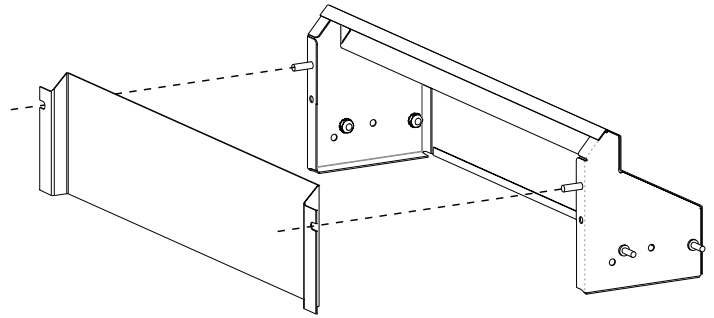

Figure 7

Install Control Panel

Attach control panel assembly to grill bottom with two (2) 10-24 keps nuts. See Figure 8.

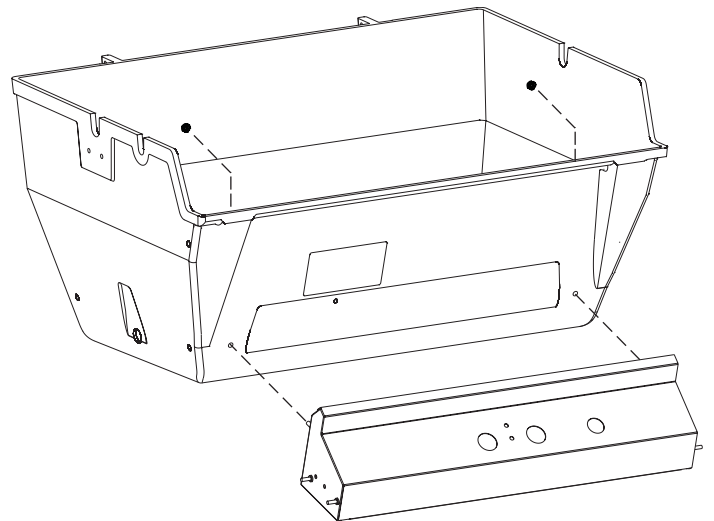

Figure 8

GRILL ASSEMBLY

Heat Shield / Wind Shield

Place the heat and wind shield in the grill bottom.
See Figure 9.

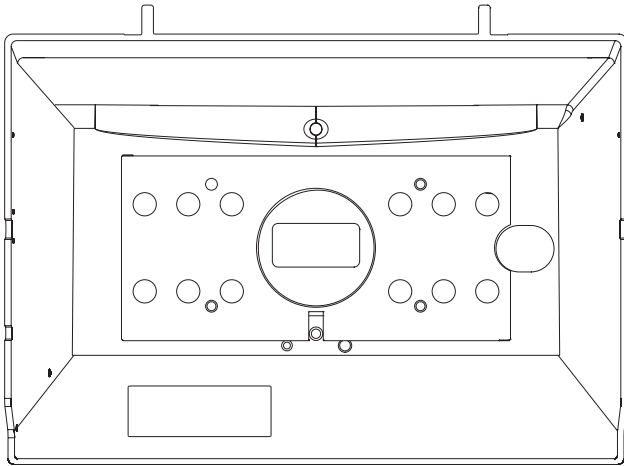

Figure 9

Burner Bracket Securing Bolt

1. Insert the 1/4-20 x 1 1/2 Phillips Truss Head Screw from the underside of the grill and secure with the 1/4-20 Hex Nut. See Figure 10.

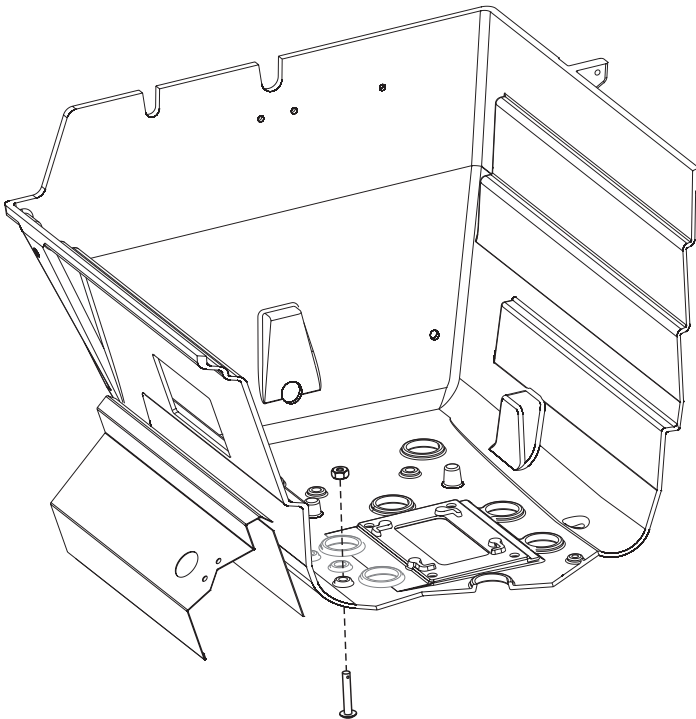

Figure 10

Note: If the Grill Head is installed on a PCB1, PSCB or DCB1, make sure the cart shield is not installed until the burner bracket securing bolt is installed.

2. Install Grill Head on a Cart or Post Mounting (see Cart or Post Installation Instructions that come with the mounting option).

Ignitor Wire

Note: Install the Ignitor Ground Wire before installing the burner.

1. Connect the ground wire to the ground lug on the collector box before installing the burner into the grill. See Figure 11.

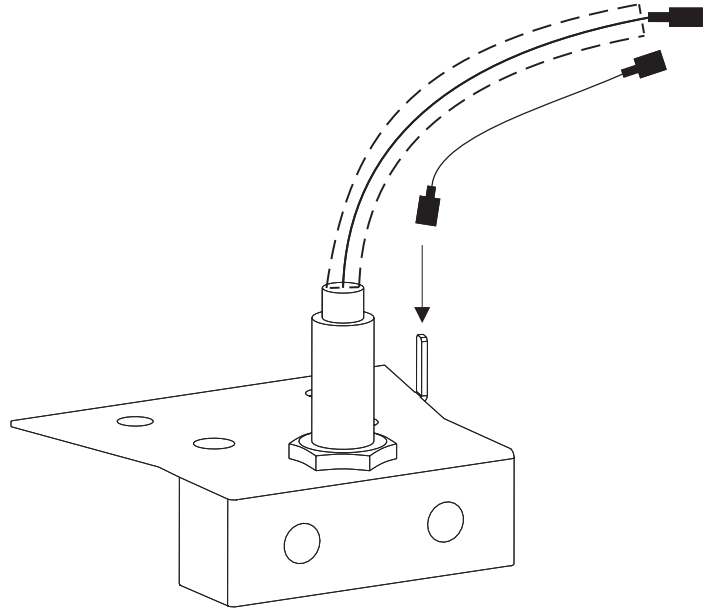

Figure 11

GRILL ASSEMBLY

Install the Burner

1. Insert the burner assembly into the grill bottom with the venturi tubes facing the front of the grill. **See Figure 12.**
2. Carefully slide the wires through the same hole in the bottom of the grill.

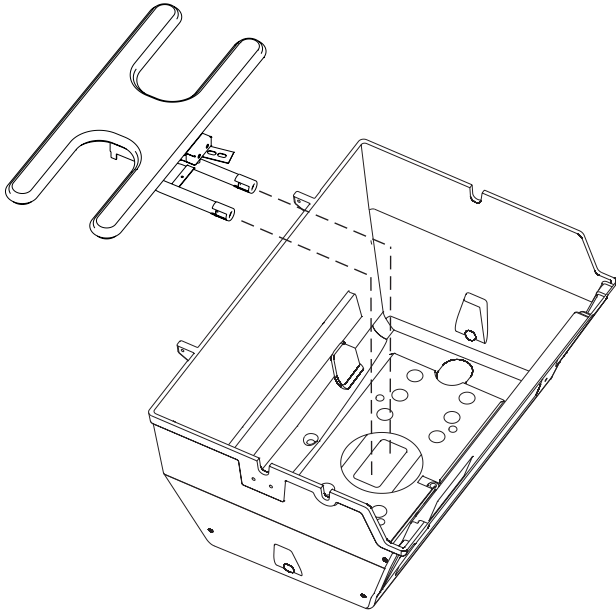

Figure 12

3. Slide the venturi on to the valve assembly.
4. Raise the unsecured end of the burner bracket and slip it over the 1/4-20 x 1 1/2 Phillips Truss Head Screw as shown in Figure 13. The screw will fit into the hole on the burner bracket.

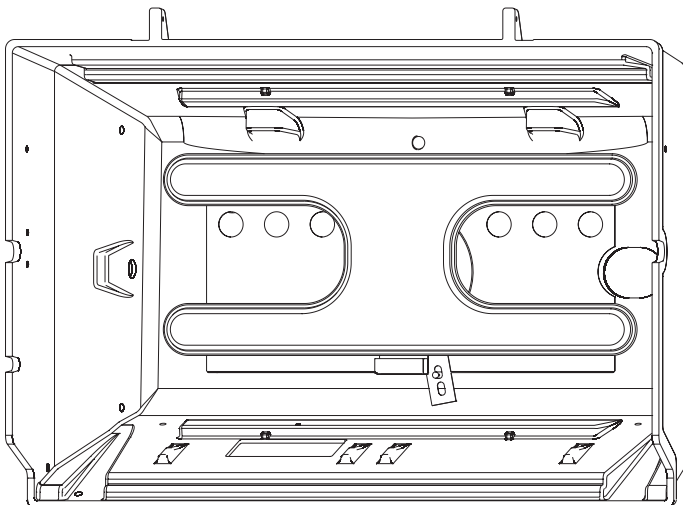

Figure 13

5. Slide the bridge pin through the hole in the 1/4-20 x 1 1/2 Phillips Truss Head Screw as shown in Figure 14.

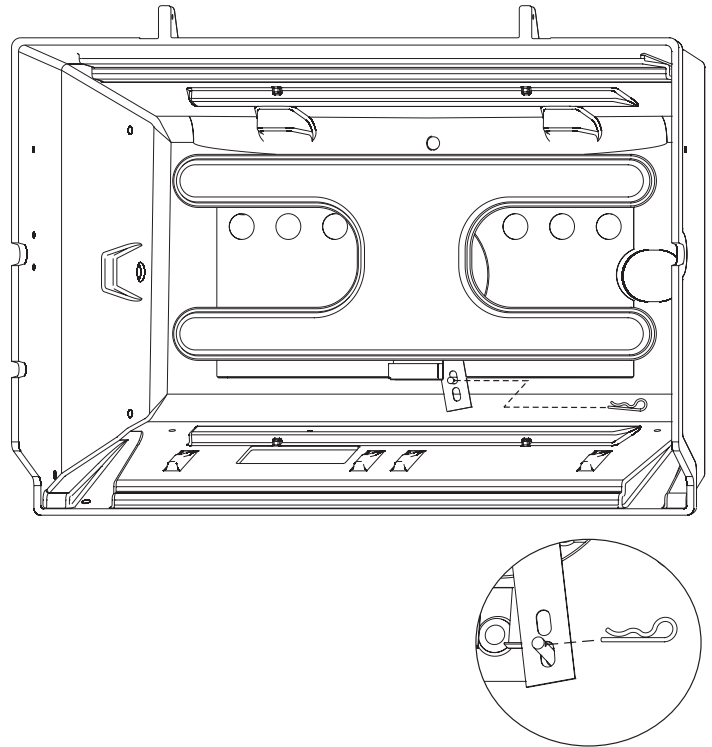

Figure 14

Connect Igniter Wires and Install Battery

1. Attach ground and igniter wires to the igniter as shown in Figure 15.
2. Remove push button cap and insert AA battery, positive side down, as shown in Figure 15.

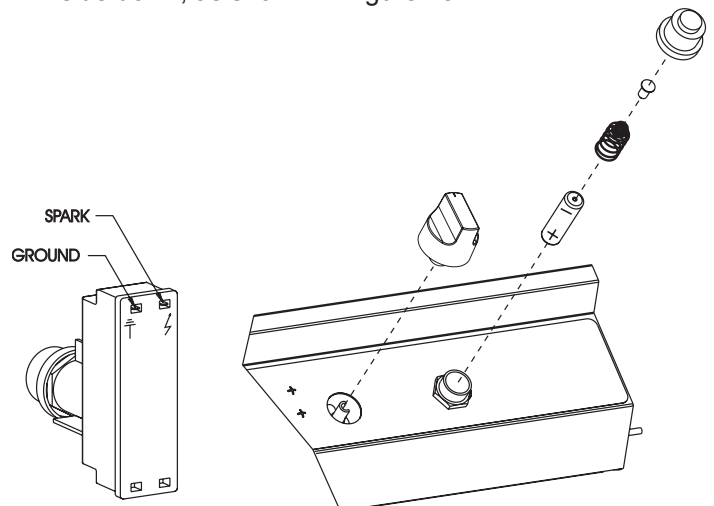
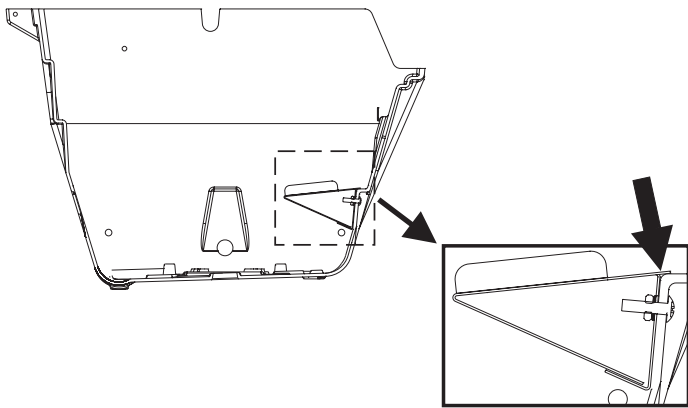
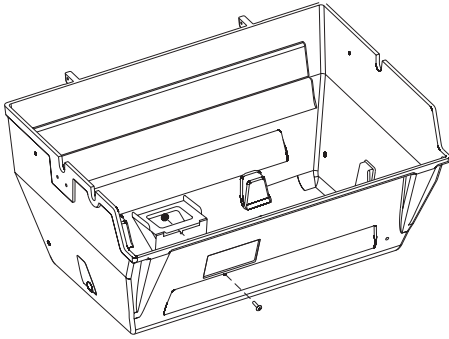

Figure 15

GRILL ASSEMBLY

Smoker Drawer

1. Attach drawer support bracket to inside front of grill body with (1) 10-24 x 3/4" machine screw and 10-24 nut. See **Figure 16**.
2. Slide the smoker box through the opening in the grill body. See **Figure 17**.



Lip resting on casting ledge

Figure 16

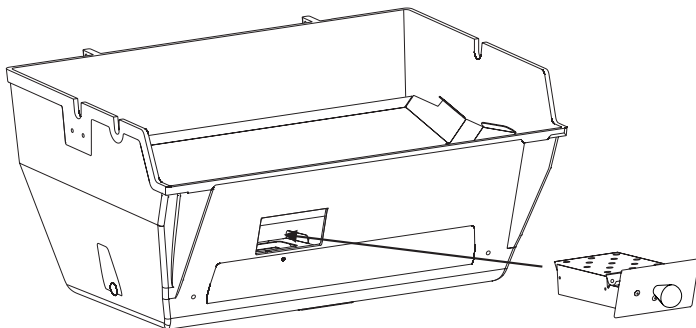

Figure 17

Reinstall Grill Body Top to Grill Body Bottom

1. Secure grill body top to grill body bottom by replacing the two hinge pins and clips. See **Figures 18 and 19**.

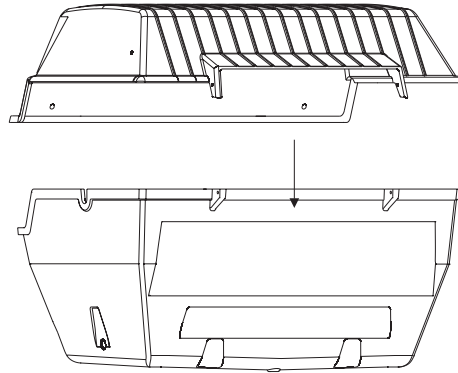

Figure 18

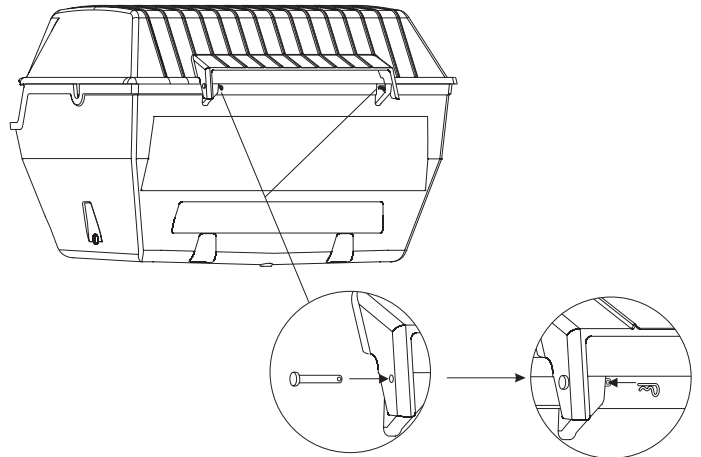

Figure 19

GRILL ASSEMBLY

Handle

For your added comfort a foam grip has been provided. See **Figure 20**.

Tip: For ease of installation, slightly lubricate the front handle with liquid soap before pushing the foam grip into place.

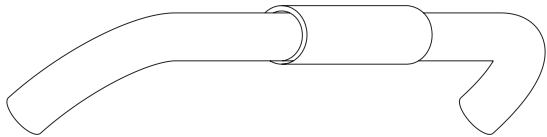

Figure 20

Fasten the front handle to the grill lid with two #10-24 x 1" screws. See **Figure 21**.

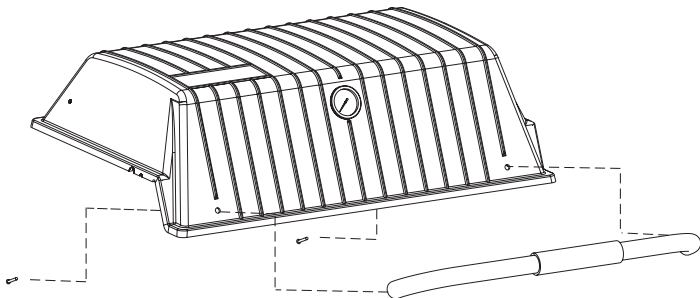

Figure 21

Note: Install side shelves or side burner to side of grill at this time. See installation instructions that came with the side shelves or side burner for more information.

Install Heat Indicator

1. Insert heat indicator probe through the hole in the grill body lid and slide on push nut to secure. See **Figure 22**.

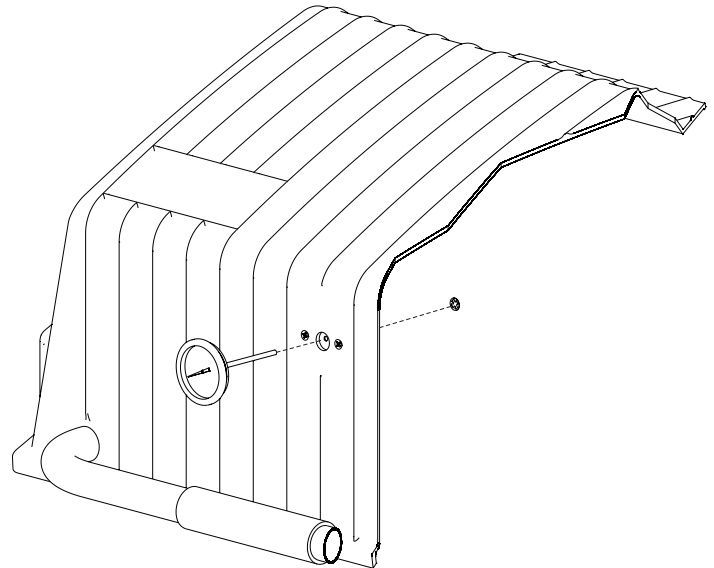

Figure 22

GRILL ASSEMBLY

Assemble Drain Pan

Note: Drain pipe and valve components are packed inside the smoker box.

1. Lightly spread pipe sealant on all threads before assembling to the drain pan.
2. Thread the 3/4" pipe into the bottom of the drain pan and tighten.
3. Assemble the two 45° elbows as shown in Figure 23.
Note: Make sure of the mountings (posts, carts, etc.) being used before tightening to ensure that the fittings are set to the proper position.

**FOR USE ON ALL POSTS
AND DCB AND PCB CARTS**

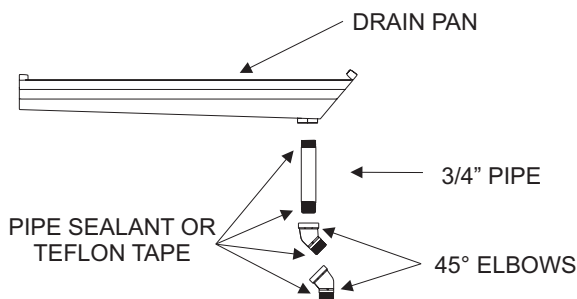

FOR USE ON PSCB CART

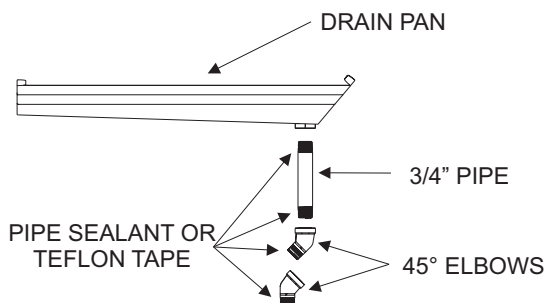

Figure 23

Install the Drain Pan Assembly

1. Lower the drain pan into the lower casting with the drain pipe on the right side. Pass the pipe through the oval hole in the bottom of the casting, making sure the pipe extends out through the bottom of the casting and the pan is sitting level on the holding tabs. **See Figure 24.**
2. Slide the drain bucket hanger into place over the pipe and screw on the drain shut off valve and tighten.
Note: Position Drain Shut Off Valve so it does not interfere with the wall of the grill head.

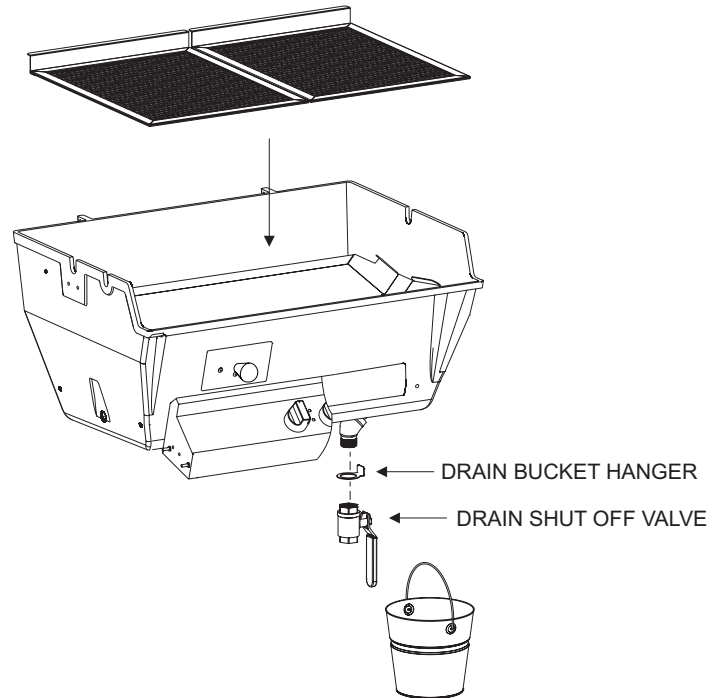

Figure 24

3. Set cooking grids in place.
Note: The grids are designed for two levels of cooking.
4. Hang the drip bucket on the drain bucket hanger.

NOTE: If the grill was installed on a cart, make sure to install the cart's heat shield before use.

OPERATION - PROPANE & NATURAL GAS GRILLS

Checking for Gas Leaks

Check for gas leaks every time you connect your Broilmaster propane gas grill to a Propane gas cylinder, when a connected cylinder has not been used recently, or when either a natural or propane grill is being used for the first time.

Caution: Do not use an open flame when checking for leaks. Checking for leaks with an open flame may lead to a fire or explosion, resulting in property damage or personal injury.

To check for gas leaks:

1. Use dish washing liquid and a little water to make a soapy solution.
2. Turn OFF the knob on the control panel.
3. Turn ON the gas at the supply or cylinder. A hissing sound indicates a leak. Turn OFF the gas and repair the leak.
4. Apply the soapy water solution to all gas connections.
5. Look for bubbles. Bubbles indicate a leak.
6. If there are bubbles turn OFF the gas and repair the leak.
7. Turn the gas back ON and repeat the above procedures until all leaks are repaired.

Air Shutter Adjustment

The venturi air shutter(s) are preset at the factory so that after five minutes the burner flames are blue with well defined cones. If, after five minutes the flame is yellow, or there is a gap between the burner and the flame, adjust the venturi air shutter as follows:

1. Turn gas OFF and let the burner cool.
2. Loosen shutter set screw
3. Close the air shutter to the minimum opening.
4. Light the burner, wait five minutes and then carefully open the air shutter until the flame is blue and well defined.
5. Retighten the set screw.

Heat Indicator Recalibration

The heat indicator can be recalibrated if needed. Remove the heat indicator from the grill and place the probe end in a pot of boiling water. Set the heat indicator by turning the nut on the back until it reads 212 degrees. The indicator is now set.

Lighting Instructions

Using the Ignitor

Caution: If a burner fails to light after 5 seconds, turn the burner OFF for 5 minutes and open grill lid, to allow the gas to clear, then try again.

1. Turn knob on the grill CLOCKWISE to the OFF position.
2. Turn ON gas at the source.
3. With the grill lid open, push and turn the burner valve knob COUNTERCLOCKWISE to HI.
4. Push and hold the ignitor button until the burner lights (approximately 5 seconds).
5. If a burner does not light, turn OFF all gas and refer to the Troubleshooting section of this manual.

Using Matches

Caution: If a burner fails to light after 5 seconds, turn the burner OFF for 5 minutes and open grill lid, to allow the gas to clear, then try again.

1. Turn knob on the grill CLOCKWISE to the OFF position.
2. Turn ON gas at the source.
3. Open the grill lid.
4. Insert a burning long wooden match through the lighter hole on either side of the grill. **See Figure 25.**
5. Turn the burner valve knob COUNTERCLOCKWISE to HI.
6. If a burner does not light, turn OFF all gas and refer to the Troubleshooting section of this manual.

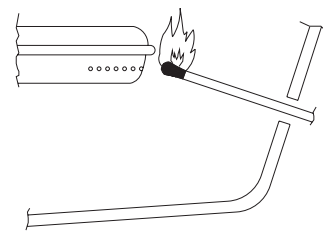

Figure 25

OPERATION

Before Cooking

Before cooking on a grill for the first time, burn off any manufacturing process oil residue.

1. Raise the grill lid.
2. Light grill burner.
3. Burn on HI for ten minutes.
4. Close the lid and burn on HI for an additional ten minutes.
5. The grill is now ready for use.

Preheating

Before cooking on a gas grill, allow the grill to preheat on HI for 15 minutes with the lid closed.

This uses very little fuel and provides better flavor.

Electrical Accessories

If an electrical accessory is used on your grill, the accessory must be electrically grounded in accordance with local codes or, in the absence of local codes, with the National Electric Code, ANSI/NFPA 70. In Canada, the electrical accessory must be electrically grounded in accordance with the applicable section of the current Canadian Electrical Code, CSA C22.1.

Any electrical accessory should be equipped with a three-prong (grounding) plug, and plugged into a properly grounded three-prong receptacle or wall outlet. Do not cut or remove the grounding prong from the plug.

If an extension cord is required, use only a three-prong cord and plug into a properly grounded receptacle as described above.

Do not expose an electrical accessory to water. Avoid using any electrical accessory in wet weather as it may present a shock hazard.

Keep any electrical cord and fuel supply hose away from all heated surfaces.

MAINTENANCE

Cleaning the Grill

Caution: To prevent injury, use care when cleaning a hot grill.

Note: Do not use a commercial cleaner on the cooking grid. Do not brush grids while they are hot. Do not scrape grids.

Grids and Drip Pan

The grids are made of high quality stainless steel and should be brushed with a brass brush while the grill is still warm. The drip pan is made of high quality stainless steel as well and can be cleaned with a scraping tool. The pan must be kept clean of heavy build-up for the grill to perform properly and to reduce flare-ups. Clean as needed or approximately every 10 uses.

Burn Off

This process is much like that used in self-cleaning ovens and is most efficient when completed after each use of the grill.

Caution: Do not open the grill during the burn off process. Opening the grill during the burn off process may cause a sudden grease fire flare up that could burn your face and arms. Wait until the grill has cooled before opening.

1. Turn gas knob to HI. Close lid and allow the grill to burn for ten minutes, or until no smoke is present. Do not allow the grill to burn for more than 30 minutes.
2. Turn gas knob and supply to OFF and allow the grill to cool.

Grill Bottom

Once or twice a year remove cooking grids and drip pan to clean the interior of the grill. Scrape off baked on residue with a putty knife or brass brush and rinse with water.

Burner Maintenance

Stainless steel burners often turn reddish brown after use. This does not effect the performance of the grill. When cleaning the interior of the grill, remove the burners and clean with a brass brush. Wash with water and a mild detergent.

Drip Pipe and Valve

Drain pipe and valve must be kept clear of grease and food particles to allow the grease to drain properly. To clear the drain pipe and valve, run a flexible drain brush through both and remove.

Bucket

The bucket can be stored under the grill lid when the grill is not in use.

Venturi Tubes

The venturi tubes allow air and gas to mix prior to burning, thus ensuring an efficient flame. Spiders or other small insects may build webs or nests inside the tubes obstructing air flow. Fire, or flashback, can occur, in and/or around obstructed venturi tubes and can cause damage to components beneath the grill or an unsafe condition. To reduce risk, inspect and clean the Venturi Tubes at least twice monthly when spiders are active. If the grill has been unused for an extended period of time inspect the tubes before using the grill.

Clean venturi tubes as follows:

1. Remove the cooking grids and drip pan.
2. Remove the burner from the grill.
3. Lay the burner face down and remove the four retaining screws from the venturi tube plate and the burner. **See Figure 26.**
4. Use a small flexible brush to remove any debris for the tube(s).
5. Flush with water.
6. Allow the tube(s) to dry before reinstalling.
7. Reinstall the venturi tubes, igniter and burner bracket to burner.

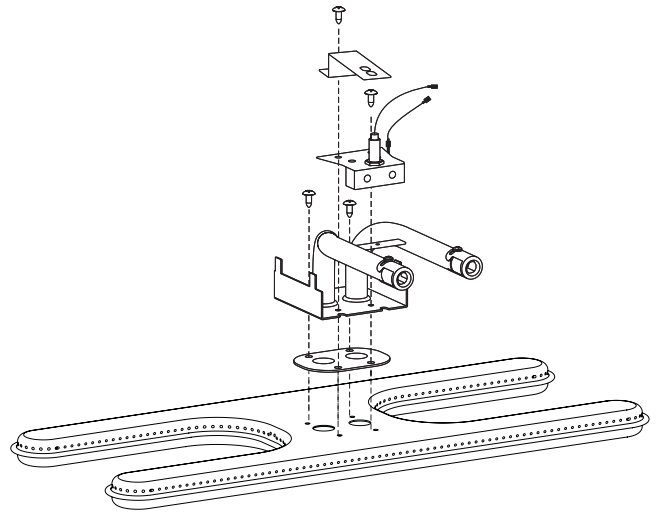

Figure 26

Exterior

Clean regularly with a solution of mild detergent and hot water. Touch-up paint is available from your dealer. Broil-master protective covers are recommended. Stainless steel components can be easily cleaned with a spray-on stainless steel cleaner found in most hardware stores.

TROUBLESHOOTING

Although the manufacturer has attempted to ensure that your grill will operate properly and satisfactorily, sometimes problems do arise. The following troubleshooting guide lists several possible problems and their probable cause and solution.

Problem	Cause	Solution
Burner will not light.	Out of gas	Refill LP gas cylinder. If natural model, turn on gas at source.
	Gas injector not inserted in venturi tube.	Realign/engage gas injector with the venturi tube.
	Clogged gas injector.	Remove gas injector from gas control assembly and clean.
	Obstruction in gas line.	For propane models, ensure gas valve on cylinder is OFF. Remove flexible hose and blow out any debris.
	Spider webs in venturi tubes.	Clean venturi tubes. See Maintenance Section.
	Misalignment of collector box and burner.	Position electrode properly. Clean collector box.
	Dead battery.	Replace with AA battery.
Inadequate grill temperature.	Poor combustion.	Adjust air shutter.
	Misalignment of venturi tube and gas injector.	Realign/engage gas injector with the venturi tube.
	Inadequate gas pressure.	Contact gas supplier for assistance.
	Incorrect orifice/valve setting.	Refer to gas conversion instructions in this manual.
Flames blow out.	Cold grill.	Preheat grill at least 15 minutes on HI with the grill lid closed.
	Misalignment of burner tube and gas injector.	Realign/engage gas injector with the burner tube.
	Poor combustion.	Adjust air shutter.
	Extreme wind.	Turn or shield grill.
Yellow flames.	Air shutter improperly set.	Open air shutter.
	Spider webs in venturi tubes.	Clean venturi tubes. See Maintenance Section.
	Seasoning salts on burner.	Clean by washing burner with mild detergent.
	Oil film on burner.	Allow burner to operate on HI for 10-15 minutes.

COOKING TIPS

Cook Food To Proper Temperatures

Cooking food safely requires that you raise the internal temperature of the meat high enough and for a long enough period of time to kill any food-borne bacteria that may cause illnesses.

Color is not the best indicator that food is safe to eat. Use a high-quality probe thermometer to be sure your food is properly cooked. Place the tip of an instant-read thermometer into the center of the thickest part of the food but at least 1/2 inch deep. Read the temperature after about 10 seconds. Follow the temperature guidelines for the type of food you're cooking.

The following guidelines are from the U.S. Food and Drug Administration Center for Food Safety and Applied Nutrition.

Cook to Internal Temp			
Meat & Poultry	Medium Rare	Medium	Well Done
Fresh Beef - Medium Rare	145°F	160°F	170°F
Ground turkey, chicken	165°F		
Ground veal, beef, lamb, pork	145°F with 3 minutes of rest and then turn		
Fresh Pork - Medium		160°F	170°F
Chicken - whole	165°F		
Turkey - whole	165°F		
Poultry breasts, roast	165°F		
Poultry thighs, wings	165°F		
Stuffing (cooked alone or in bird)	165°F		
Duck and goose	180°F		
Fresh Veal - Medium Rare	160°F		
Fresh Lamb - Medium Rare	145°F	160°F	170°F
Ham - fresh (raw)	145°F	160°F	170°F
Ham - pre-cooked (reheat)	140°F		
Seafood			
Fish	Cook until flesh turns opaque and flakes easily with a fork.		
Shrimp, lobster, crab	Cook until shells turn red and flesh becomes pearly opaque.		
Scallops	Should turn milky white or opaque and firm.		
Clams, mussels, oysters	Cook until shells open.		

The Qrave Grill is an indirect gas grill. This means that the flame never comes in contact with the food and does not flare up. The drip pan vaporizes all the drippings into smoke and moisture. This produces tastier and juicier foods. You will be amazed at how easy it is to cook all your favorites and more; perfect every time.

The following instructions are to be used as a guideline. You may need to adjust the cooking times and temperatures to suite your own taste.

When cooking on the Qrave Grill, it is essential that the lid remain closed. This not only keeps the temperature constant, but holds in the moisture as well.

The drip pan drain valve should be open when grilling. This allows the excess grease to continuously drain into the catch bucket. The only time the drain valve should be closed is when cooking with a liquid in the pan.

Quick Temperature Reference		
Valve Knob Setting	Approximate Temperatures	Types of Cooking
One Valve Knob Low	220°F to 250°F	Slow Cooking & Smoking
Both Valve Knob Low	320°F to 350°F	Roasting & Baking
Both Valve Knob Medium	375°F to 425°F	Roasting & Baking
Both Valve Knob High	450°F to 550°F	Grilling & Steaming

*The above temperature settings are a guide, the temperatures may vary due to wind and outside ambient temperatures.

COOKING TIPS

Grilling

1. Place the cooking grids in the low position.
2. Preheat your grill with both valve knobs set to High for 15 minutes.

We recommend that when grilling, the valve knobs should remain on high. This cooking method is great for hamburgers, steaks, chops, etc.

Roasting

When roasting it is important to remember that it is just like cooking in your oven. Hint: You may want to fill the drip pan with water or a marinade to create more flavor and moisture.

1. Close the drip pan drain valve and fill the pan about half full with water or marinade.
2. Set the cooking grids at the low position.
3. Preheat the grill with both controls on High for 15 minutes.
4. Set the valve knobs to the desired temperature using the Quick Temperature Reference Chart.

While cooking, monitor the heat indicator on the grill and adjust temperature as necessary.

More water or marinade may need to be added to the pan as it evaporates during cooking.

Roasted chicken, turkey or pork roasts will never taste better.

Baking

Before starting, make sure the drip tray is clean.

1. Place the cooking grids at the high position to remove the food away from the direct heat.
2. Preheat your grill with both valve knobs set to High for 15 minutes.
3. Set the valve knobs to the desired temperature using the Quick Temperature Reference Chart.

Use the heat indicator on the grill to more accurately adjust the temperature.

Even cookies, pizza and desserts can be made on the Grave Grill.

Steaming

Before starting, make sure the drip tray is clean.

1. Set the cooking grids at the low position.
2. Close the drip pan drain valve and fill pan with water. Be careful not to over-fill the pan.
3. Preheat your grill with both valve knobs set to High for 15 minutes.
4. The valve knobs will remain on high for steaming. Cook until desired taste. More liquid may need to be added to the pan as it evaporates during cooking.

Vegetables and seafood taste great when steamed in the Grave Grill.

Smoking

The Grave Grill is equipped with a front load smoker box.

1. Soak your flavor smoking chips in water for about 15 minutes. This will make the chips burn slower and create more flavor.
2. Remove the smoker box and fill with the soaked chips and then replace.
3. Set the cooking grids at the low position.
4. Preheat your grill with both valve knobs set to High for 15 minutes or until you detect smoke.
5. Place the food on the grill and adjust the temperature as desired.

Note: The left knob controls the amount of heat under the drip tray.

This works great for adding smoke flavor when grilling and roasting.

Slow Cooking with Smoking

The Grave Grill has dual controls for more control for those low temperatures needed for slow cooking.

1. Adjust the cooking grids to the high position.
2. Close the drain valve and add water or marinade to the drip pan. It is recommended to slow cook with a liquid in the pan to keep the food from drying out. More liquid may need to be added to the pan as it evaporates during cooking.
3. Preheat your grill with both valve knobs set to High for 15 minutes.
4. Turn off the right valve knob and turn the left valve knob to low. Hint: The left valve knob controls the heat on the smoker box. Add water-soaked flavor chips to the smoker tray as needed. Most chips will last about an hour before needing to be replaced.

Turn the food once an hour when slow cooking.

Slow cooking with a Grave Grill could mean the best ribs or brisket your family has ever tasted.

CAUTION: Always use an oven mitt when removing smoker box while grill is hot. Make sure chips are cooled before emptying smoker box.

GRILL MAINTENANCE HISTORY

Date	Maintenance Performed

GRILL MAINTENANCE HISTORY

Date	Maintenance Performed

COOKING TIPS

Your Broilmaster Premium Gas Grill is identified by model number, serial number, and gas type. This information is provided on a product identification label located on the grill's control panel. For your convenience, complete this section for future reference when contacting your dealer.

Model No. _____ Dealer _____

Serial No. _____ Dealer Phone No. _____

Gas Type: Propane _____ Natural _____ Date of Purchase _____



BROILMASTER

A Division of Empire Comfort Systems, Inc.

918 Freeburg Ave.

Belleville, Illinois 62220

VISIT OUR WEB SITE AT www.broilmaster.com

If you have a general question about our products, please e-mail us at info@empirecomfort.com.

If you have a service or repair question, please contact your dealer.